

Toyota Supra front installation guide

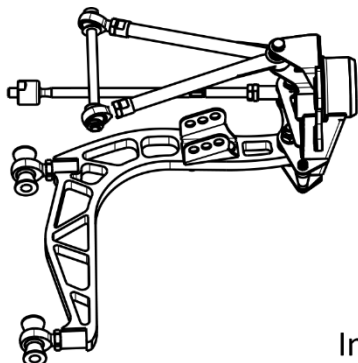

Overall view of assembled components in the right corner

All lengths (exc. tie rod) are pre set by Wisefab. No need to adjust before alignment.

Installing the upper A arms

Upper arms are symmetrical.

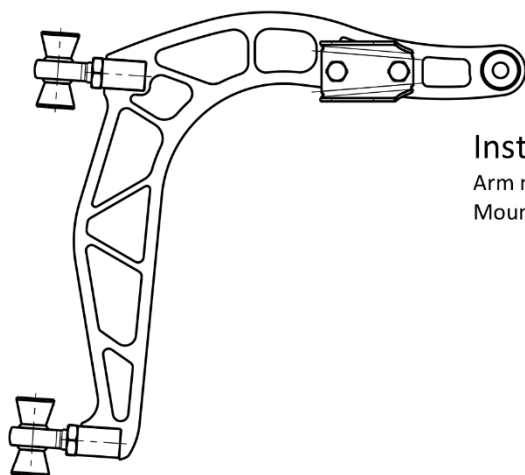
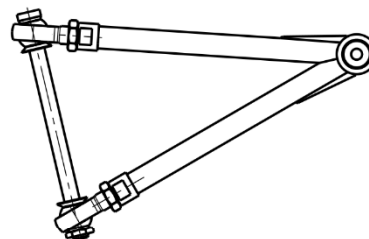

Installing the lower arms.

Arm must be installed to the lower position.

Mount arms with stock bolts, we recommend using new ones.

Adjusting suspension stiffness

You can adjust motion ratio ride/roll stiffness by changing the coilover mounting point on arm.

Moving it outwards, ride/roll will be stiffer.

Moving it inwards, ride/roll will be softer.

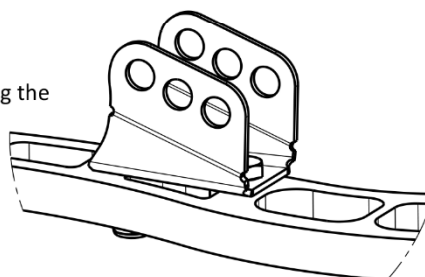

Recommended alignment specs

Camber: -3,3 +/- 0,3

Caster: 3 +/- 0,3

Toe: If ackerman is 0 or negative then toe is 2 mm out.

If ackerman is positive then toe is 0



If you still have some trouble installing the kit, contact us at

sales@wisefab.com, or call us +372 5562 5669