

Nissan Z370-Chassis installation guide

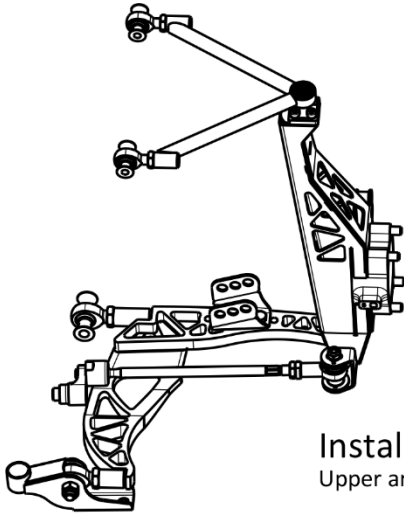

Overall view of assembled components in the right corner

All lengths (exc. tie rod) are pre set by Wisefab. No need to adjust before alignment.

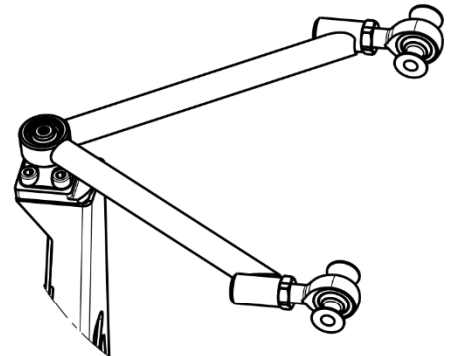

Installing the upper A arms

Upper arms are symmetrical.

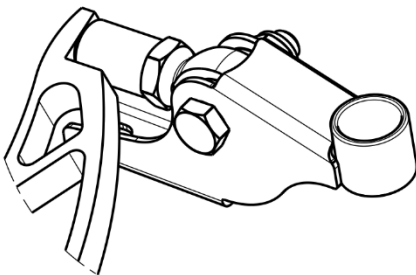

Installing the lower arms.

Install the special mounting jig to the subframe before installing the arm. Mount arms with stock bolts, we recommend using new ones.

Installing the rack offset spacer

Before installing the rack offset spacer clean the ends of the steering shaft where the spacers goes. After cleaning use thread lock on the spacer itself and shaft

When installing the rack offset spacer, be sure it faces forward and little bit upwards.

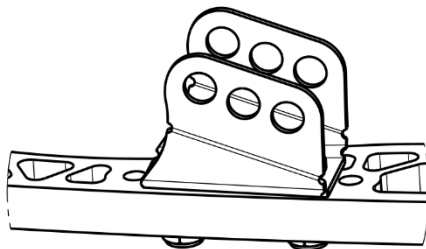
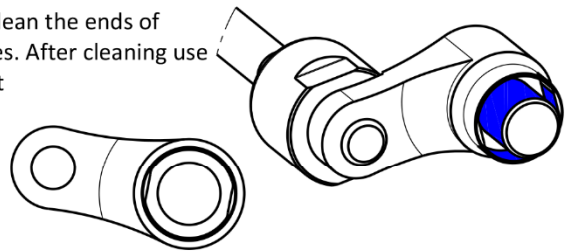

Adjusting suspension stiffness

You can adjust motion ratio (ride/roll stiffness) by changing the coilover mounting point on arm.

Moving it outwards, ride/roll will be stiffer.
Moving it inwards, ride/roll will be softer.

Recommended alignment specs

Camber: -3,7 +/- 0,3

Caster: 6,3 +/- 0,3

Toe: 0...-2



If you still have some trouble installing the kit, contact us at sales@wisefab.com, or call us +372 5562 5669