

BMW e30, e36, e46 installation guide

This installation guide has been made using BMW e36 as an example, installation principal is same on e30, e36, e46 and e46M models. For the assembly stiffness the upright bottom flat surfaces must be straight and clean of rust. Check if those 2 upright bottom surfaces fit with full contact to Wisefab upright support. If there are some high spots then machine them down. If somebody have used a hammer to remove suspension joint from upright, then there are some deformed edges that need to be removed either with file or angle grinder.



Installing the lower control arm

When installing the A-arm to the subframe tighten the conical bolt to the subframe first (Pic 1) then fasten the inner hex bolt at the bottom of the arm, use thread lock (Pic 2).

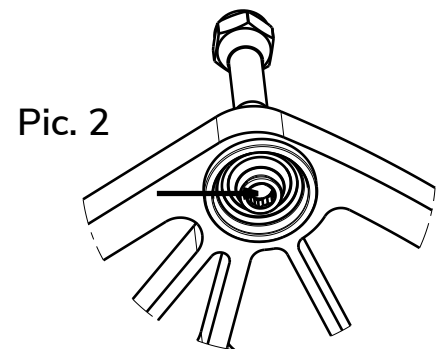
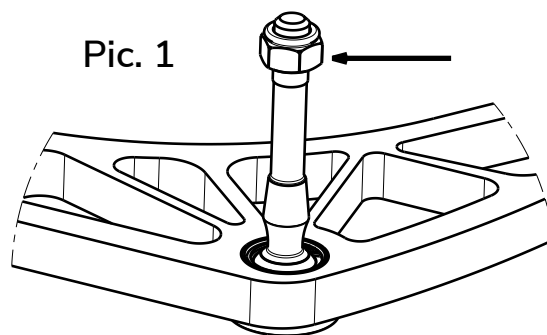

Installing the camber plates

We have set the optimum position for maximum performance (A)
When tightening the bolts the maximum torque is 50Nm (B)

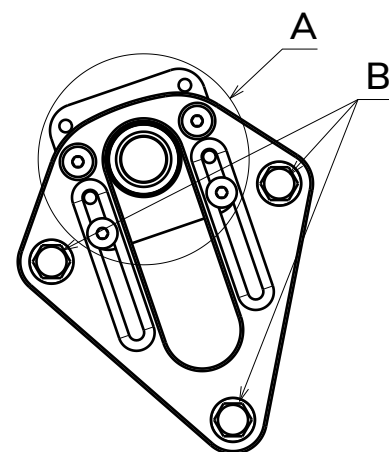

Installing the tierods on E30 chassis

Wisefab setup on E30 chassis requires E36 inner tierod.
We recommend using a new tierod.



If you still have some trouble installing the kit, contact us at sales@wisefab.com, or call us +372 5562 5669

BMW e30, e36, e46 installation guide

Installing the knuckle add-ons

When assembling the Wisefab upright support, then tighten first the upper nuts of the custom conical bolts, then lower ones (Pic 3). Use thread lock! When everything is assembled, then check if rims have enough clearance with wishbone. If not then add some spacers, use narrower rims or different offset rims.

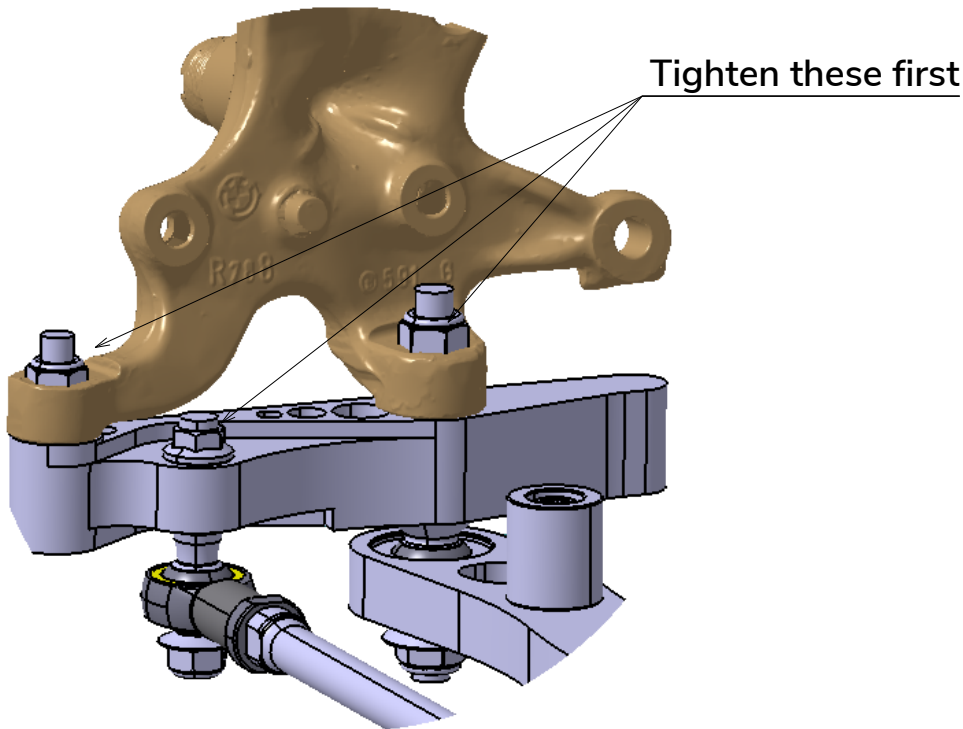

After first event, check if all the bolts and nuts are still tight!

Recommended alignment parameters

Chassis	Camber	Caster	Toe
E30	-7	8	0
E36	-5	4,5	0
E46	-4	5	0
E46M	-4	5	0



If you still have some trouble installing the kit, contact us at sales@wisefab.com, or call us +372 5562 5669