

Chevrolet Corvette C5/C6 Front lock kit

Overall view of assembled components in the right corner

All lengths are preset (exc. tie rod). Bolts and nuts may needed to loosen to make your assembling easier. OEM anti-roll bar may need to be modified to fit and can't be used with high wheel angles.

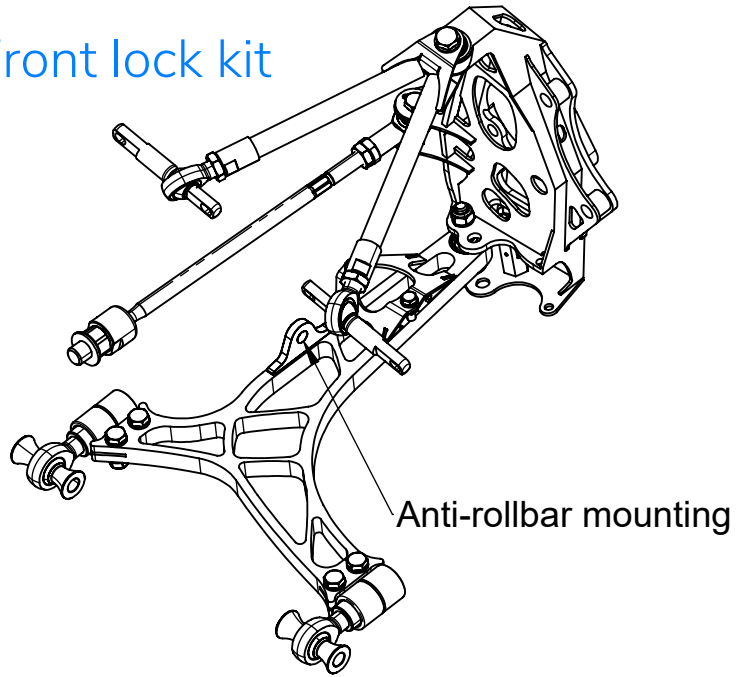

Install the Lower Arm

Lower arm has built in camber/caster adjustment with Double Adjusters. Adjusting both adjusters the same way - camber is adjusted. Adjusting adjusters the opposite way - caster is adjusted.

How to adjust Double Adjuster

Step 1: Loosen Rod end locking nut with 8 mm Allen key

Step 2: Loosen bolts

Step 3: Adjust Double Adjuster with 10 mm Allen key for caster adjustment

Step 4: Tighten the bolts

Step 5: Lock the Rod end locking nut with 8 mm Allen key

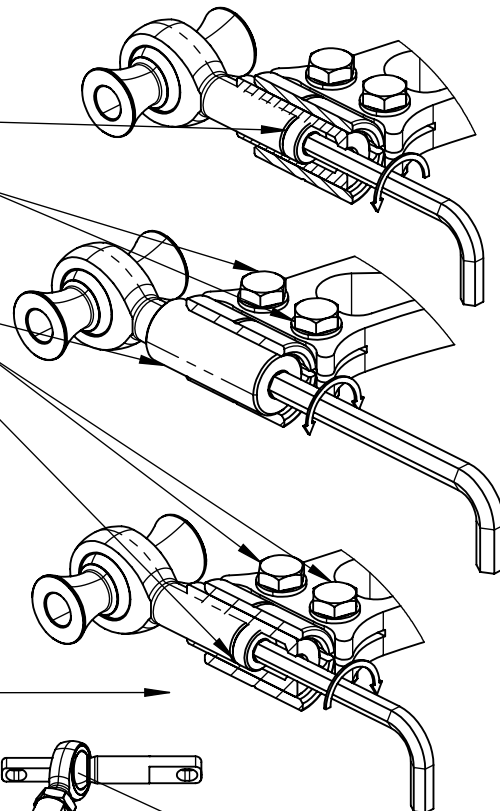

Installing the Upper Arm

Make sure that shorter link is facing forward
Body mountings must be positioned as shown (shorter side inside)
Tighten rod ends after tighten the body mountings.

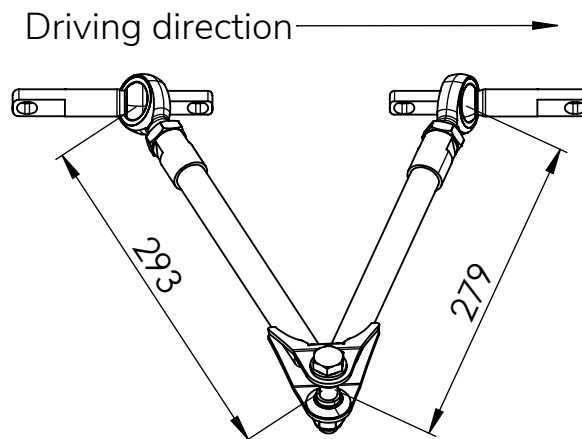

If you still have some trouble installing the kit, contact us at sales@wisefab.com, or call us +372 5562 5669

Installing the Knuckle

Take a spacers from upper arm and press them into knuckle upper spherical bearing by tightening M12 bolt. All the surfaces must be parallel while tightening.

Connect brake caliper using OEM bolts.

Connect hub with OEM bolts, but use 3x M12 washers which came with knuckles.

Mount the Lower Arm where shown

Place a lock stopper as shown

Lock stopper adjustment

Wisefab lock kits are equipped with hexagonal lock stoppers, where each side has a different offset. The more dimples, the more offset and by that less usable lock.

When installing, make sure that Tie rod is not binding in any way.

Installing the Tie rod

Connect the tie rod with the rod end fitted to the knuckle. Upper spacer must be 9 mm high and lower spacer 13 mm

Ackermann

C5 and C6 have different tie rod fixing points to get near parallel steering. For C5 use 0 Ackermann washer but for C6 use 3mm Ackermann washer. Tie rod fixing has to be moved towards the wheel. If Wisefab rack offsets are used on a C6 then use 0 Ackermann washer.

Recommended Alignment Specs

Camber: -3.5°

Caster: 6°

Toe: if ackerman is 0 or negative then toe is 2mm
if ackerman is positive then toe is 0

Wheel Backspacing (A) max: " 17" wheel - 145 mm

18" wheel - 147 mm

19" wheel - 150 mm

Some 17" wheels may not fit

Coilover: length (B): Rideheight 378 mm

Maximum: 430 mm

Minimum 345 mm

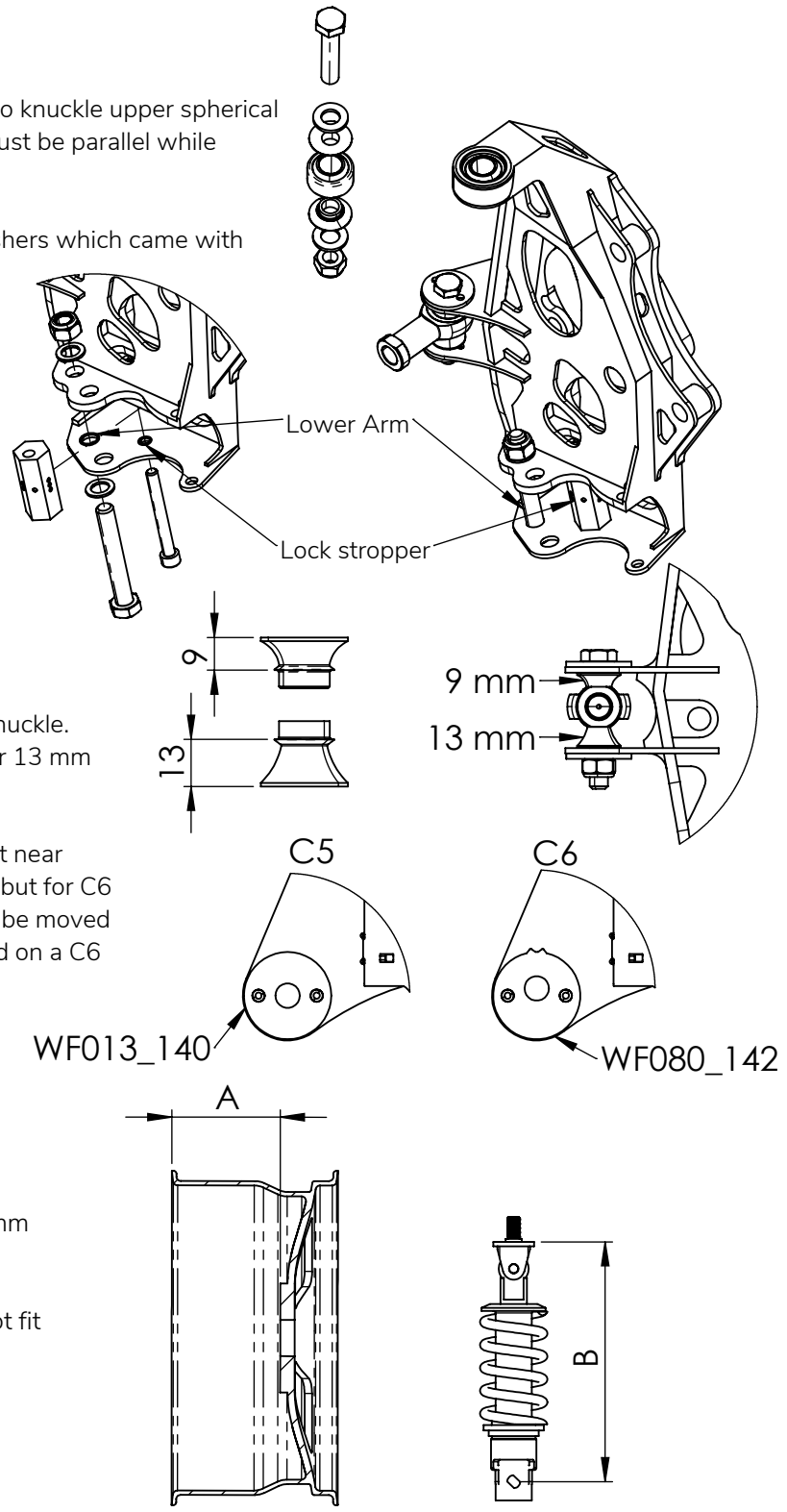

Important information

After installment check for clearance issues between car body and other suspension components. Make sure that nothing is fouling throughout all of suspension travel with suitable wheel. For that the Coilover has to be removed.

In case of interferences make corrections in alignment or limit useable lock.



If you still have some trouble installing the kit, contact us at sales@wisefab.com, or call us +372 5562 5669